

BRD-355

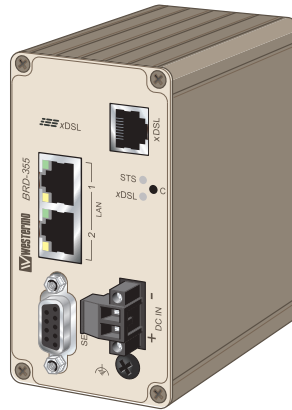

Industrial ADSL/VDSL Router

Legal information

The contents of this document are provided "as is". Except as required by applicable law, no warranties of any kind, either express or implied, including, but not limited to, the implied warranties of merchantability and fitness for a particular purpose, are made in relation to the accuracy and reliability or contents of this document. Westermo reserves the right to revise this document or withdraw it at any time without prior notice.

Under no circumstances shall Westermo be responsible for any loss of data or income or any special, incidental, and consequential or indirect damages howsoever caused.

More information about Westermo can be found at the following Internet address:

<http://www.westermo.com>

Safety



Before installation:

Read this manual completely and gather all information on the unit. Make sure that you understand it fully. Check that your application does not exceed the safe operating specifications for this unit.

The unit must be installed by a service person and connected to a protective earthing contact. Disconnect all telecommunication network connectors and cable distribution system connectors before disconnecting the protective earthing contacts.

This unit should be built-in to an apparatus cabinet, or similar, where access is restricted to service personnel only.

The power supply wiring must be sufficiently fused, and if necessary it must be possible to disconnect manually from the power supply. Ensure compliance to national installation regulations.

This unit uses convection cooling. To avoid obstructing the airflow around the unit, follow the spacing recommendations (see Cooling section).

This unit uses negative earth, therefore the 0 V and protective earth must be connected to ensure robust functionality.



Before mounting, using or removing this unit:

Prevent access to hazardous voltage by disconnecting the unit from power supply. Warning! Do not open connected unit. Hazardous voltage may occur within this unit when connected to power supply.

Care recommendations

Follow the care recommendations below to maintain full operation of unit and to fulfil the warranty obligations.

This unit must not be operating with removed covers or lids. Do not attempt to disassemble the unit. There are no user serviceable parts inside. Do not drop, knock or shake the unit, rough handling above the specification may cause damage to internal circuit boards. Do not use harsh chemicals, cleaning solvents or strong detergents to clean the unit. Do not paint the unit. Paint can clog the unit and prevent proper operation. Do not expose the unit to any kind of liquids (rain, beverages, etc). The unit is not waterproof. Keep the unit within the specified humidity levels. Do not use or store the unit in dusty, dirty areas, connectors as well as other mechanical parts may be damaged.

If the unit is not working properly, contact the place of purchase, nearest Westermo distributor office or Westermo Tech support.

Maintenance

No maintenance is required, as long as the unit is used as intended within the specified conditions.

Agency approvals and standards compliance

Type	Approval / Compliance
EMC	EN 61000-6-1, Immunity residential environments
	EN 61000-6-2, Immunity industrial environments
	EN 61000-6-3, Emission residential environments
	EN 61000-6-4, Emission industrial environments
Safety	EN 60950-1, IT equipment

Declaration of Conformity, BRD-355



Westermo Teleindustri AB

Declaration of Conformity

The manufacturer Westermo Teleindustri AB
SE-640 40 Stora Sundby, Sweden

Herewith declares that the product(s)

Type of product	Model	Art no
ADSL / VDSL Router	BRD-355	3623-0311

is in conformity with the following EU directive(s).

No	Short name
2014/30/EU	Electromagnetic Compatibility (EMC)
2014/35/EU	Low Voltage Directive (LVD)
2011/65/EU	Restriction of the use of certain hazardous substances in electrical and electronic equipment (RoHS)

References of standards applied for this EU declaration of conformity.

No	Title	Issue
EN 55024	Information technology equipment – Immunity characteristics – Limits and methods of measurement	2010 +A1:2015
EN 55032	Information technology equipment – Radio disturbance Characteristics – limits and methods of measurement	2014
EN 60950-1	Information technology equipment -- Safety -- General requirements	2006 +A11:2009 +A1: 2010 +A12:2011 +A2: 2013
EN 50581	Technical documentation for the assessment of electrical and electronic products with respect to the restriction of hazardous substances	2012



Signature

Pierre Öberg
Technical Manager
4th October 2017

Postadress/Postal address
S-640 40 Stora Sundby
Sweden

Tel. 016-428000
Int+46 16428000

Telefax 016-428001
Int+46 16428001

Postgiro 52 72 79-4

Bankgiro 5671-5550

Org.nr/
Corp. identity number 556361-2604

Registered office
Eskilstuna

Type tests and environmental conditions

Phenomena	Test	Description	Test levels
ESD	EN 61000-4-2	Enclosure contact	± 6 kV (crit A)
		Enclosure air	± 8 kV (crit A)
Radiated RF immunity	IEC 61000-4-3	Enclosure	20 V/m (crit A) (80 – 2700 MHz)
Fast transient	EN 61000-4-4	DC power ports	± 2 kV (crit A)
		Ethernet ports	± 2 kV (crit A)
		Serial port	± 2 kV (crit B)
		xDSL ports	± 2 kV (crit B)
Surge	EN 61000-4-5	DC power ports	± 2 kV (crit A), 42 Ω ± 500 V (crit A), 12 Ω
		Ethernet ports	± 2 kV (crit A), (shielded cable)
		xDSL ports	± 2 kV (crit B)
RF conducted	EN 61000-4-6	DC power ports	10 V/m, (crit A), (0.15 – 80 MHz)
		Ethernet ports	3 V/m, (crit A), (0.15 – 80 MHz) 10 V/m, (crit B), (0.15 – 80 MHz)
		xDSL ports	3 V/m (crit A), (0.15 – 80 MHz) 10 V/m (crit B), (0.15 – 80 MHz)
Radiated emission	CISPR 16-2-3	Enclosure	EN 61000-6-3
Conducted emission	CISPR 16-2-1	DC power ports	EN 61000-6-3
	CISPR 32	Ethernet ports	
		xDSL port	
Temperature	EN 60068-2-1 EN 60068-2-2	Operating	-25 to +70°C (-13 to +158°F)
		Storage & Transport	-40 to +85°C (-40 to +185°F)
Humidity	EN 60068-2-30	Operating	0 to 90% relative humidity non condensing.
		Storage & Transport	0 to 90% relative humidity non condensing.
Altitude		Operating	2000 m / 70 kPa
Service life		Operating	10 year
Dimension W x H x D			53 x 103 x 97 mm (2.08 x 4.05 x 3.81 in)
Weight			0.40 kg
Degree of protection	IEC 529	Enclosure	IP 40
Cooling			Convection
Mounting			Horizontal on 35 mm DIN-rail

Description

Remote access removes boundaries, eliminates the need for time consuming site visits and provides a network infrastructure suitable for today's "always-on" society. The BRD-355 is an industrially designed xDSL (ADSL/VDSL2) broadband router built to cope with harsh environments and the characteristics of industrial applications. The unit supports a wide range of xDSL-standards and has support for long lines.

Most devices today comes equipped with an Ethernet port for communications, therefore the BRD-355 has a built-in two port Ethernet switch. For legacy connectivity the unit also features one RS-232-port to provide multiple connection possibilities for both new and legacy replacement installations. Designed to be installed on a DIN-rail all connectors and LEDs have been positioned in the front of the unit, facing the user for easy access and fast status feedback. With wide power input range, the unit can be powered from 10 to 60 VDC and has low power consumption.

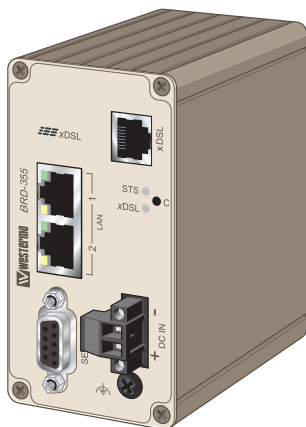

The cyber security features of the BRD-355 prevent unauthorized access and secure the communication for Internet-enabled applications. The easy to use firewall filters incoming traffic, allowing only approved packets to pass through. To inter-connect units with each other securely over the Internet multiple VPN technologies are supported, including IPsec and OpenVPN.

Upgrading legacy solutions to become IP-enabled can prove both costly and tedious therefore the BRD-355 includes a wide feature set for various legacy applications including both modem replacement methods as well as serial to Ethernet conversion. If there are applications that require extra attention Westermo's extensive experience from over 35 years within industrial data communications and over 5 years of industrial xDSL expertise will be available to assist you.

Interface specifications

Power	
Rated voltage	12 – 48 VDC
Operating voltage	10 – 60 VDC
Operational current (max)	450 mA @ 12 VDC
Rated current (max)	1000 mA @ 12 VDC
Rated frequency	DC

RS-232	
Electrical specification	EIA RS-232
Data rate	300 bit/s – 115.2 kbit/s
Data format	7 or 8 data bits, Odd, even or none parity, 1 or 2 stop bits
Protocol	Transparent, optimised by packing algorithm
Circuit type	SELV
Transmission range	15 m / 49 ft
Connection	9 pin D-sub female
Shielded cable	Not required
Conductive housing	Yes
Number of ports	1

Ethernet TX	
Electrical specification	IEEE std 802.3. 2005 Edition
Data rate	10 Mbit/s, 100 Mbit/s, manual or auto
Duplex	Full or half, manual or auto
Circuit type	SELV
Transmission range	100 m / 328 ft
Isolation to	All other
Connection	RJ-45 auto MDI/MDIX
Shielded cable	Not required
Conductive housing	Yes
Number of ports	2

DSL				
Protocol	LLC/VC-MUX encap Ethernet, PPPoA, PPPoE, IPoA			
Connection	1 x RJ-11			
Version	Common name	Standard	Downlink	Uplink
ADSL	ADSL	ANSI T1.413	8 Mbit/s	1.0 Mbit/s
	ADSL (G.dmt)	ITU G.992.1	8 Mbit/s	1.0 Mbit/s
	ADSL (G.lite)	ITU G.992.2	1.5 Mbit/s	0.5 Mbit/s
	ADSL over POTS	ITU G.992.1 Annex A	12 Mbit/s	1.3 Mbit/s
	ADSL over ISDN	ITU G.992.1 Annex B	12 Mbit/s	1.8 Mbit/s
ADSL2	RE-ADSL	ITU G.992.3 Annex L1/L2	5 Mbit/s	0.8 Mbit/s
	ADSL2	ITU G.992.3	12 Mbit/s	1.3 Mbit/s
	ADSL2 Annex J	ITU G.992.3 Annex J	12 Mbit/s	3.5 Mbit/s
ADSL2+	ADSL2+	ITU G.992.5	24 Mbit/s	1.4 Mbit/s
	ADSL2+ Annex M	ITU G.992.5 Annex M	24 Mbit/s	3.3 Mbit/s
VDSL2	VDSL2	ITU G.993.2*	100 Mbit/s**	100 Mbit/s**
	VDSL2 Vectoring	ITU G.993.5 G.Vector	100 Mbit/s**	100 Mbit/s**

* Supports profiles 8a, 8b, 8c, 8d, 12a, 12b, 17a, 30a.

** Maximum sustained routing performance over time is around 35 Mbit/s.

Connections

Ethernet TX Connections (RJ-45 connector) LAN1-2

Position	Direction	Description
1	In/Out	TD+
2	In/Out	TD-
3	In/Out	RD+
4	-	Not Connected
5	-	Not Connected
6	In/Out	RD-
7	-	Not Connected
8	-	Not Connected

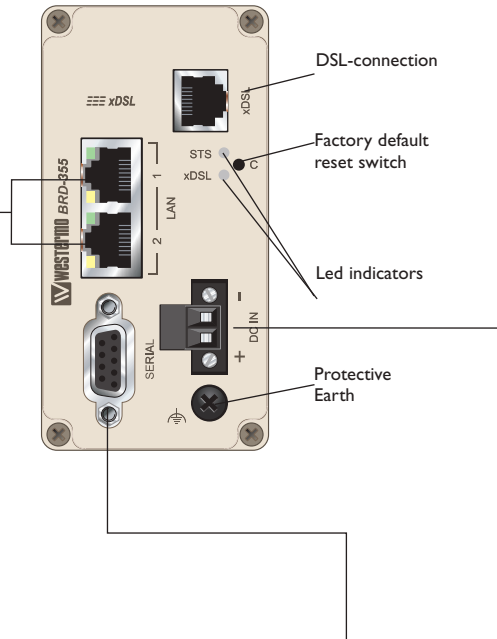

Router Serial Port (DCE Female)

Position	Name	Direction	Description
1	DCD	Out	Data Carrier Detect
2	RxD	Out	Receive Data
3	TxD	In	Transmit Data
4	DTR	In	Data Terminal Ready
5	SG	-	Signal Ground
6	DSR	Out	Data Set Ready
7	RTS	IN	Request to Send
8	CTS	Out	Clear to Send
9	RI	Out	Ring Indicator

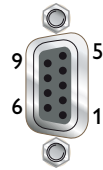

Power connector

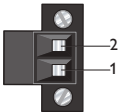
	2-position	Product marking	Direction	Description
	No. 1	+	Input	Supply voltage input DC
	No. 2	-	Input	Common

LED Indicators

LED	Status	Description	
STS Status	RED	Indicates a fault, except during boot-up	STS ●
	RED FLASH	Indicates a fault, except during boot-up	
	GREEN	All OK	
	GREEN & ONE RED FLASH	All OK but no VPN peer connected	
xDSL Link status	OFF	No ADSL connection	xDSL ●
	GREEN FLASH	Negotiating with the provider DSLAM	
	GREEN	All OK, ADSL link established	

STS LED – Status indicator

The status indicator reports the health of the unit. In normal operation the indicator will be green, however, if a fault is detected, either at boot-up or during normal operation, the indicator will light red. When the unit is first switched on or is reset, the indicator will first light red then flash red. This is normal behavior during boot-up and does not indicate a fault.

Configuring a VPN connection in the BRD-355 and activating the service will cause the STS LED to be lit GREEN but FLASH RED every third (3) second to indicate that no peer is connected on the VPN. The feature of the VPN status in the STS LED makes it easy for staff to see whether or not the VPN connection is working without having to login to the device.

DSL LED – xDSL link status

The DSL LED reports the status of the connection to the network. When powered up the indicator will be off, the indicator will then flash green whilst the unit tries to negotiate the link with the provider DSLAM, once successfully connected to the provider the indicator will light green to indicate that everything is ready and functioning on the xDSL link level.

Factory Default Reset Switch

The reset switch is used to restore the configuration of the BRD-355 to the factory default settings (for details about the default settings see the Getting started section). The switch is accessed through a small hole, adjacent to the xDSL and STS LEDs, labeled C on the front of the unit.

To reset the configuration:

- Power down the unit.
- Using a suitable tool depress the reset switch.
- Power up the unit ensuring the switch remains depressed for approximately 5 seconds after power is applied. The STS LED will flash twice to indicate a reset.
- Once the unit has booted-up it will use the default settings.

Note: Using the factory default reset switch will erase all existing configuration settings and restore the factory default settings.

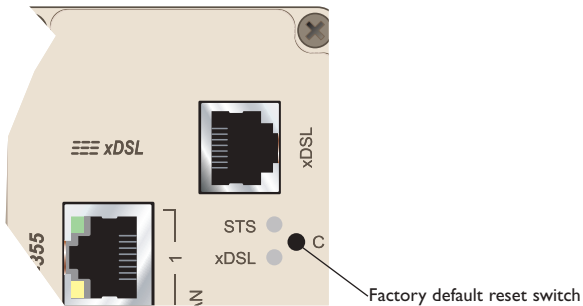

Protocols and Functionality

Ethernet Technologies	IEEE 802.3 for 10BaseT IEEE 802.3u for 100BaseTX Layer-2 QoS IEEE 802.1p Class of Service
xDSL Technologies	RFC2684 Bridged LLC and Bridged VC-MUX ATM encap. (ADSL) TR-067 Compliance Dying Gasp support ITU K.21 Support Rate adaptive modem at 32 Kbps steps ATM Layer with traffic shaping QoS support (UBR, CBR, VBR-rt,VBR-nrt) AAL5 – AAL F5 OAM Loopback/Send and receive RFC2364 PPPoA client support RFC2516 PPPoE client support RFC2225 / RFC1577 Classical IP Support PAP/CHAP/MS-CHAP for Password Authentication support
Serial Port Technologies	RS-232 Serial Over IP (Serial Extender and Virtual Serial Port) Modem emulation AT command interpreter MODBUS DNP3
IP Routing, Firewall, VPN and Cyber Security	Static IP routing Dynamic IP routing • RIPv1/v2 VRRP GRE Stateful inspection Firewall / ACL, NAT, Port Forwarding 25 x IPsec VPN, PSK & X.509 1 x L2TP client 1 x PPTP client 1 x OpenVPN / SSL VPN client RADIUS PPP Dial in/Dial out
Manageability	Management tools • Web-interface (HTTP and HTTPS) • Command Line Interface (CLI) via SSHv2 and TELNET • SNMPv1/v2c/v3 Syslog (log files) SNTP (NTP client) DHCP client DHCP server DDNS (Dynamic DNS update client)

For more information on the features and functionality, please refer to the Management Guide on the product website.

Getting started

Power Supply

The BRD-355 requires a DC power source in the voltage range of 10 to 60 VDC. The unit is designed to self protect from permanent damage if the voltage exceeds 60 VDC or if reverse polarity is applied. The router may need to be returned for service if this occurs. The router can also be damaged if there is any potential difference between the chassis-ground, RS-232 signal ground or power (-) input. Before connecting any wiring, ensure all components are earthed to a common ground point. An external isolator will be required if a positive earth power supply is used.

Ethernet

The Ethernet ports are on the front of the unit and are marked LAN 1 and LAN 2, each port has a LED indicating the connection speed and a LED indicating activity as shown in figure below. Both ports are capable of auto-negotiation, meaning cross-over cables are not required. The Ethernet ports are switched, allowing more than one Ethernet device to be connected to the unit at one time.

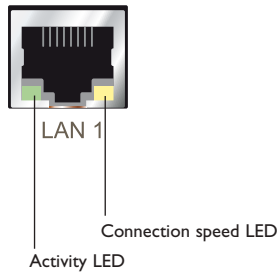

Configuration

Accessing and Using the Web Interface

All configuration of the BRD can be done via the web interface. In order to view the web pages a computer with a fixed IP address, on the same sub-net as the BRD, will need to be connected to one of the LAN ports.

The default IP settings of the BRD are:

- IP Address: 192.168.2.200
- Netmask: 255.255.255.0

The recommended IP settings for the PC used to configure the BRD Router:

- IP Address: 192.168.2.100
- Netmask: 255.255.255.0
- Default Gateway: 192.168.2.200
- Primary DNS: 192.168.2.200

Note: Although it is possible to connect the BRD directly to a Local Area Network (LAN) it is recommend that the network configuration as described in this section is performed prior to doing so. The DHCP server of the unit is by default disabled.

Windows PC Network Settings

The following describes how to configure the network settings of a PC with Windows 7 so that it can access the BRD.

Note: This procedure will change the network settings of the Windows PC, if the PC is connected to a network the connection should be removed before performing the changes. To restore the network settings of the PC, record the current settings at Step 7 in the following procedure. When the BRD has been configured, follow the procedure again and use the recorded values at Step 7.

1. Open the Control Panel by selecting Start > Control Panel.
2. Click the Network and Sharing Center icon.
3. Click Change Adapter Settings.
4. Double click the Network icon.
5. The Local Area Connection Status dialog box will be displayed, click the Properties button.
6. The Local Area Connection Properties dialog box, as shown in Figure 1, will be displayed
Click on Internet Protocol (TCP/IPv4) to highlight it and then click the Properties button.

Figure 1

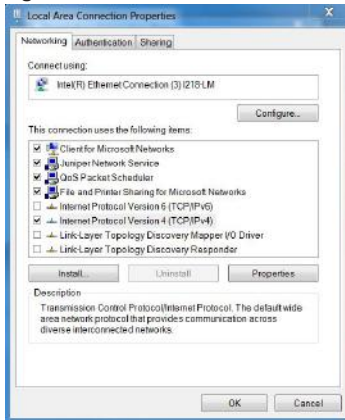

7. The Internet Protocol (TCP/IP) Properties dialog box, change the settings to match those shown in Figure 2, and then click "OK."

Figure 2

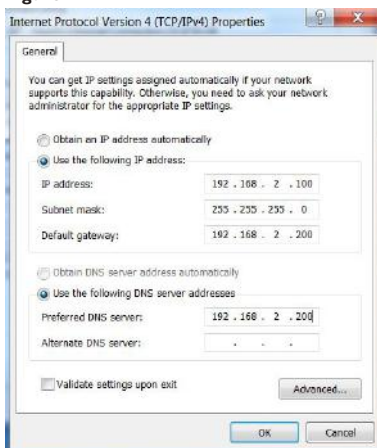

Note: If a web browser was open prior to making the network changes, it will need to be closed and re-started before attempting to connect to the BRD.

Mounting

This unit should be mounted on 35 mm DIN-rail, which is horizontally mounted inside an apparatus cabinet or similar. Snap on mounting, see figure.

Mounting the BRD-355 with integrated DIN-clip:

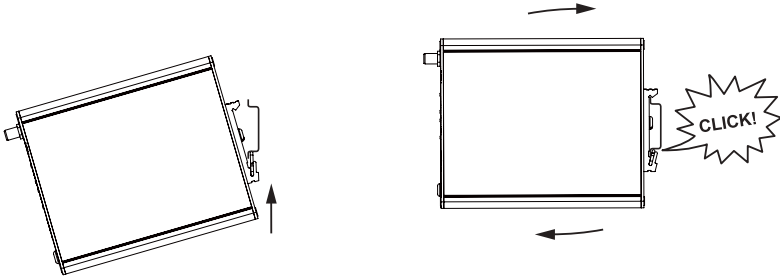

Cooling

The router should be mounted in a clean and dry location, protected from water, excessive dust, corrosive fumes, extremes of temperature and direct sunlight. Allow sufficient ventilation to ensure adequate cooling of the router.

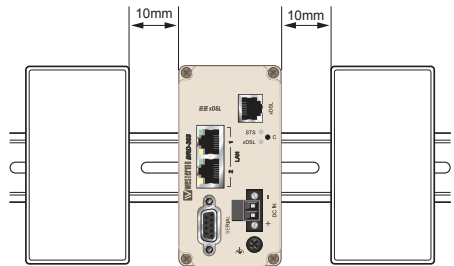

Dimensional drawing

(mm)

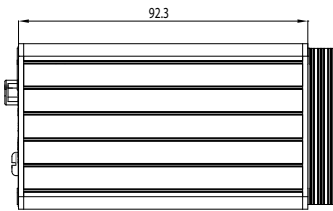
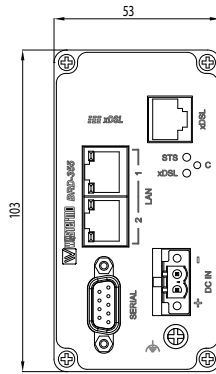
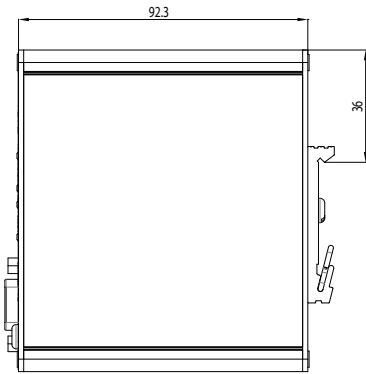



Westermo • SE-640 40 Stora Sundby, Sweden
Tel +46 16 42 80 00 Fax +46 16 42 80 01
E-mail: info@westermo.com
www.westermo.com

Sales Units

Westermo Data Communications

Australia

info@westermo.net.au
www.westermo.net.au

China

sales.cn@westermo.com
www.cn.westermo.com

Finland

tiedot@westermo.fi
www.westermo.fi

France

infos@westermo.fr
www.westermo.fr

Germany

info@westermo.de
www.westermo.de

North America

info@westermo.us
www.westermo.us

Singapore

sales@westermo.com.sg
www.westermo.com

Sweden

info.sverige@westermo.se
www.westermo.se

United Kingdom

sales@westermo.co.uk
www.westermo.co.uk

Other Offices



For complete contact information, please visit our website at www.westermo.com/contact or scan the QR code