

Moxa TCC-100/100I User's Guide

Seventh Edition, June 2008

www.moxa.com/product

MOXA[®]

© 2008 Moxa Inc., all rights reserved.
Reproduction without permission is prohibited.

Moxa TCC-100/100I User's Guide

The software described in this manual is furnished under a license agreement and may be used only in accordance with the terms of that agreement.

Copyright Notice

Copyright © 2008 Moxa Inc.

All rights reserved.

Reproduction without permission is prohibited.

Trademarks

MOXA is a registered trademark of Moxa Inc.

All other trademarks or registered marks in this manual belong to their respective manufacturers.

Disclaimer

Information in this document is subject to change without notice and does not represent a commitment on the part of Moxa.

Moxa provides this document “as is,” without warranty of any kind, either expressed or implied, including, but not limited to, its particular purpose. Moxa reserves the right to make improvements and/or changes to this manual, or to the products and/or the programs described in this manual, at any time.

Information provided in this manual is intended to be accurate and reliable. However, Moxa assumes no responsibility for its use, or for any infringements on the rights of third parties that may result from its use.

This product might include unintentional technical or typographical errors. Changes are periodically made to the information herein to correct such errors, and these changes are incorporated into new editions of the publication.

Technical Support Contact Information
www.moxa.com/support

Moxa Americas:

Toll-free: 1-888-669-2872

Tel: +1-714-528-6777

Fax: +1-714-528-6778

Moxa China (Shanghai office):

Toll-free: 800-820-5036

Tel: +86-21-5258-9955

Fax: +86-10-6872-3958

Moxa Europe:

Tel: +49-89-3 70 03 99-0

Fax: +49-89-3 70 03 99-99

Moxa Asia-Pacific:

Tel: +886-2-8919-1230

Fax: +886-2-8919-1231

Table of Contents

| | | |
|-------------------|-----------------------------------|------------|
| Chapter 1 | Introduction..... | 1-1 |
| | Overview | 1-2 |
| | Product Features | 1-4 |
| | Package Checklist..... | 1-4 |
| | Product Specifications | 1-4 |
| | Schematic | 1-6 |
| | LED Indicators | 1-6 |
| | | |
| Chapter 2 | Installation..... | 2-1 |
| | Hardware Installation | 2-2 |
| | Termination Resistor Diagram..... | 2-7 |
| | Function Diagram..... | 2-7 |
| | Isolation Block Diagram..... | 2-8 |
| | Typical Applications | 2-8 |
| | | |
| Appendix A | Service Information | A-1 |
| | Moxa Internet Services..... | A-2 |
| | Problem Report Form..... | A-3 |
| | Product Return Procedure..... | A-4 |
| | Revision History..... | A-5 |

TCC-100/100I is an RS-232 to RS-422/485 media converter. Note that TCC-100I comes with 2 KV isolation protection.

The following topics are covered in this chapter:

- Overview**
- Product Features**
- Package Checklist**
- Product Specifications**
- Schematic**
- LED Indicators**

Overview

Introduction

Many important devices used in today's industrial environment are still designed for use with an RS-232 interface. The reason is due in part to tradition, and in part to convenience. RS-232 hardware is relatively easy to design, and the device can be readily connected to most PCs. The drawback is that RS-232 is a point-to-point interface, and it imposes a distance limitation of only 15 meters between the device and the computer.



To overcome these limitations, many users employ RS-232 to RS-422/485 converters, allowing RS-232 devices to connect to an industrial RS-422 or RS-485 network and transmit data over distances up to 1.2 km. The RS-422/485 standards overcome the distance limitation by using a differential signal for transmitting data and control signals. Transmission distance and multi-drop connections are not the only issues of importance for industrial applications. In addition, housing, wiring, power supply, and over-surge protection are also serious concerns.

TCC-100I provides isolation protection for users who need an industrial grade interface conversion product to extend RS-232 transmission distance and increase networking capability. Its superior industrial application design, which includes DIN-Rail mounting, terminal block wiring, external terminal block power, and optical isolation for system protection, makes TCC-100I suitable for use in critical industrial environments. Simply put, your RS-232 devices can be used as part of an industrial RS-422/485 network, but without any hardware or software changes.

RTS/CTS RS-422 Handshaking Signals

TCC-100/100I provides RS-422 handshaking signal support. The RTS and CTS signals help solve the RS-422 signal handshaking problem and reduce data transmission errors.

Built-in RS-485 ADDC™ Intelligence

ADDC™ (Automatic Data Direction Control), a Moxa leading technology, uses a clever hardware solution to manage RS-485's data flow control problem.

ADDC™ is a hardware data flow solution that automatically senses and controls data direction, making the handshaking signal method obsolete.

Isolation

Moxa's electrical isolation technology uses two photo couplers to create a gap in each electrical signal. One photo coupler transforms the electrical signal into a light signal, which is transmitted across a small gap, and then the other photo coupler transforms the light back into an electrical signal. In this way, the two electrical circuits are completely isolated from each other, limiting the damage that could otherwise be caused by power surges in the electrical signal.

Reverse Power Protection

The Reverse Power Protection feature provides extra protection against accidentally connecting the power cables to the wrong terminal. The converter is designed to automatically detect which power wire is positive and which is negative, and then adjust the power supply accordingly.

DIP Switch Selectable Terminator

For many products of this type, the termination resistor is set by a jumper located inside the product's casing, so that the user must open the casing to disable or change the resistor's strength. Moxa offers a better solution. TCC-100/100I's terminator is set with a DIP Switch located on the outside of the converter's casing.

Auto Baud Rate Detection

TCC-100/100I incorporates a method for automatically detecting the serial signal's baud rate by hardware. This is an extremely convenient feature for the user. Even if a device's baud rate changes, the signal will still be transmitted through the RS-232 to RS-422/488 converter without any problem.

Product Features

- RS-232 to RS-422 conversion with RTC/CTS support
- RS-232 to 2/4-wire RS-485 conversion
- Detachable wall and DIN-Rail mounting for easy RS-422/485 wiring
- PWR, Tx, and Rx LEDs
- 16 KV ESD Surge Protection
- 2 KV Isolation (TCC-100I) for both power and RS-422/485 signals
- Operating temperature from -20°C to 60°C

Package Checklist

Before installing Moxa TCC-100/100I, verify that the package contains the following items:

- TCC-100 or TCC-100I
- User's Manual (this document)
- Warranty Booklet

Please notify your sales representative if any of the above items is missing or damaged.

Product Specifications

Model Names TCC-100, TCC-100I

Communication

RS-232 Signal Supports Tx, Rx, DTR, DSR, RTS, CTS, DCD;
Female DB9 interface

RS-422/485 Signal Terminal Block connector (DIP Switch selectable)
4-wire RS-422 (with RTS/CTS), up to 10 nodes (1.2 km)
4-wire RS-485: up to 32 nodes (1.2 km)
2-wire RS-485: up to 32 nodes (1.2 km)

RS-485 Data Direction Control ADDC™

Baud Rate 50 bps to 230.4 Kbps

Surge Protection 16 KV ESD RMS, for all signals

Isolation 2 KV (TCC-100I) for both Power and Signal

Environment

Operating Temperature -20 to 60°C (-4 to 140°F)

| | |
|---------------------|---------------------------|
| Storage Temperature | -20 to 85°C (-4 to 185°F) |
| Humidity | 5 to 95 %RH |

Power

| | |
|--------------------------|---|
| Input Power Voltage | External Power 12-30 VDC, Terminal Block |
| Reverse Power Protection | Protects against V+/V- reversal |
| Over Current Protection | Protects against 2 signals shorted together |
| Power Consumption | 400 mA (max.) at 12V |

Mechanical

| | |
|------------------------------|---|
| Dimensions (W × D × H) | 67 × 100 × 22 mm (without DIN-Rail mounting kit) 90 × 100 × 22 mm (with DIN-Rail mounting kit) |
| Case | Aluminum |
| Plug-In Screw Terminal Block | #22 – #16 AWG |
| Weight | 148±5 g |

Regulatory Approvals CE, FCC (Class B)

-
- WARNING**
1. This unit is not meant to be sold to consumers. It will only be shipped to manufacturers of factories.
 2. The DC source should come from an external adapter or 12 to 48 VDC source (not from DC mains) by using a transfer device.
 3. This unit should be installed or set up by a qualified service person.
-

Schematic

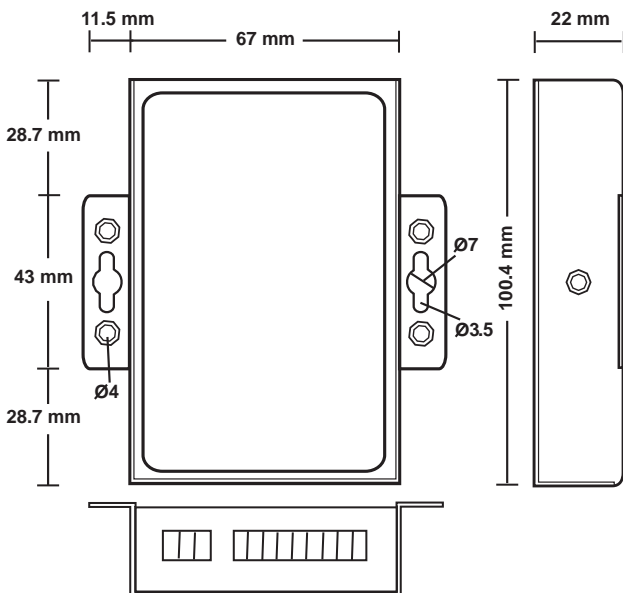

LED Indicators

TCC-100/100I's top panel contains three LED indicators, as described in the following table:

| LED Name | LED Function |
|----------|---|
| PWR | Red indicates the power is on. |
| ⏏ | Green indicates TCC-100/100I is receiving data from the RS-232 port. |
| ⏏ | Yellow indicates TCC-100/100I is receiving data from the RS-422/485 port. |

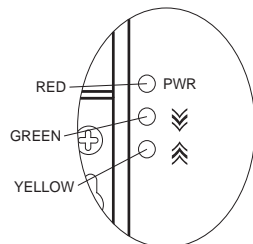

This chapter includes information about how to install TCC-100/100I, as well as function and block diagrams.

The following topics are covered in this chapter:

- ❑ **Hardware Installation**
- ❑ **Termination Resistor Diagram**
- ❑ **Function Diagram**
- ❑ **Isolation Block Diagram**
- ❑ **Typical Applications**

Hardware Installation

Installing TCC-100/100I involves five straightforward steps:

- **STEP 1:** Set the DIP Switches
- **STEP 2:** Attach the Power Supply
- **STEP 3:** Wire the Terminal Block
- **STEP 4:** Attach the RS-232 Converter
- **STEP 5:** Test the Connection

The details of each of these five steps are described next.







STEP 1: Set the DIP Switches

The DIP Switches on TCC100/100I are used to set the signal transmission mode and enable or disable the termination resistor. You can configure for either RS-422 or RS-485 transmission mode. Your program and serial port should be set to match the converter's settings.

SW1—Switch 1 selects RS-422 or RS-485 mode. The default is “On” for RS-422 mode.

SW2—Switch 2 selects 2-wire or 4-wire RS-485 mode. The default is “On” for 4-wire RS-485. Note that if Switch 1 is set to RS-422 mode, then Switch 2 is inactive.

SW3—Switch 3 enables the terminator to 120 Ohms. When enabled, the 120 Ohm resistor prevents signal reflection during RS-485 transmission. The default is “On” to enable the terminator. If your particular application does not require using the termination resistor, then simply set Switch 3 to the off position to disable it.

| Dip Switch Settings | | | | |
|---------------------------------|-----|-----|-----|---|
| RS-422 Terminator active | SW1 | SW2 | SW3 |  |
| | ON | ON | ON | |
| RS-422 | SW1 | SW2 | SW3 |  |
| | ON | ON | OFF | |
| 4-wire RS-485 Terminator active | SW1 | SW2 | SW3 |  |
| | OFF | ON | ON | |
| 4-wire RS-485 | SW1 | SW2 | SW3 |  |
| | OFF | ON | OFF | |
| 2-wire RS-485 with Terminator | SW1 | SW2 | SW3 |  |
| | OFF | OFF | ON | |
| 2-wire RS-485 | SW1 | SW2 | SW3 |  |
| | OFF | OFF | OFF | |

Moxa TCC-100/100I User's Guide

The newly implemented DIP-2 Switches are used to configure the pull high/low resistors for different applications.

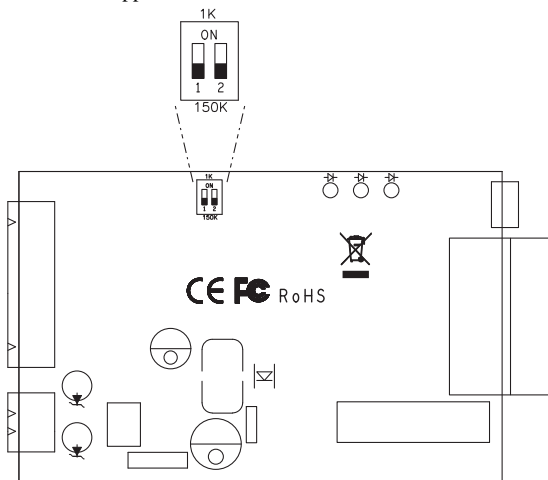

| Pull High/Low Resistor | DIP-2 SW1 | DIP-2 SW2 |
|------------------------|-----------|-----------|
| 150K (default) | OFF | OFF |
| 1K | ON | ON |

NOTE We recommend setting the pull high/low resistor to 1K (ON/ON) when termination is enabled.

STEP 2: Attach the Power Supply

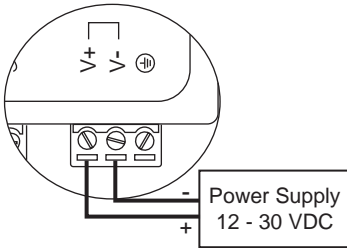

TCC-100/100I is powered by an external 12-30 VDC power supply. To connect the power supply, run two wires from the V+ and V- terminals on TCC's 3-connector terminal block to the DC power supply, as shown in the figure. Once the power supply is connected to its power source, the PWR LED located on TCC's top panel should become illuminated in red.

NOTE: TCC-100/100I provides reverse power protection. I.e., it will automatically detect which power wire is negative, and which is positive.

STEP 3: Wire the Terminal Block

There are three wiring options available for connecting to TCC-100/100I's RS-422/485 terminal block.

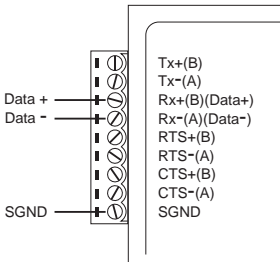

2-wire RS-485

When using the 2-wire RS-485 wiring option, connect three wires from TCC-100/100I's terminal block to the opposite connection. As shown in the figure, connect from Data+ to Data+, from Data- to Data-, and from SGND to SGND.

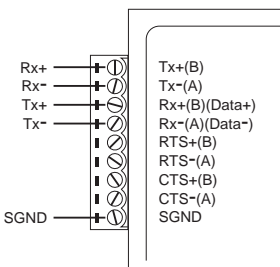

4-wire RS-485

When using the 4-wire RS-485 wiring option, connect five wires from TCC-100/100I's terminal block to the opposite connection. As shown in the figure, connect from Tx+(B) to Rx+, from Tx-(A) to Rx-, from Rx+(B) to Tx+, from Rx-(A) to Tx-, and from SGND to SGND.

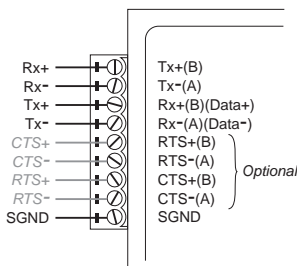

RS-422

When using the RS-422 wiring option, first follow the 4-wire RS-485 wiring instructions given above.

Optional RTS/CTS Handshaking Signals

If your software is set up to send and receive RTS/CTS signals over separate wires, you should also connect from RTS+(B) to CTS+, from RTS-(A) to CTS-, from CTS+(B) to RTS+, and from CTS-(A) to RTS-.

STEP 4: Attach the RS-232 Connector

Depending on your application, use the appropriate serial cable to connect from CC-100/100I's RS-232 Female DB9 port to your RS-232 device, or to your computer's COM port.

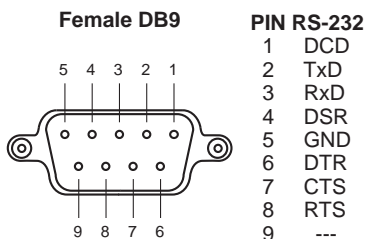

RS-232 Pin Assignment Diagram

STEP 5: Test the Connection

After setting the DIP Switches, connecting the power, wiring the terminal block, and attaching the RS-232 connector, we suggest using a Console Terminal program, such as HyperTerminal or Moxa Terminal Emulator, to test the connection. If you have an RS-422/485 serial board (such as Moxa CP-132, a 2-port RS-422/485 board) installed in your PC, you can connect your PC's COM port to TCC-100/100I's RS-232 port, and then connect TCC-100/100I's RS-422/485 terminal block to one of the RS-422/485 serial board's ports. Alternatively, if you have already set up an RS-422 or RS-485 network, you can also connect TCC-100/100I's RS-422/485 terminal block directly to that network. Next, start HyperTerminal or Moxa Terminal Emulator, and then open a connection to both the COM port, and the port associated with TCC-100/100I's RS-422/485 port. Simply type a few characters on your PC's keyboard. The characters you type should show up in the HyperTerminal window that is currently inactive, indicating that the typed characters were transmitted between TCC-100/100I's RS-232 port and RS-422/485 terminal block connector.

Termination Resistor Diagram

Termination is designed to mitigate noise from the RS-422/485 transmission signals. If the network cable is too long, undesirable transmission-line effects will arise. The best method for mitigating energy on an unused conductor is to dissipate the

energy as heat by terminating both ends of the unused conductor to ground with resistors (so-called bi-directional termination). The resistance of the resistors should be equal to the characteristic impedance of the line. The most common RS-485 twisted pair has a characteristic impedance of 100-120 Ohm. Moxa's termination technique is bi-directional termination, which offers excellent signal integrity. With this technique, the line drivers can be located anywhere on the network.

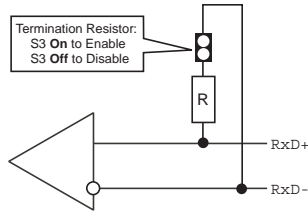

Function Diagram

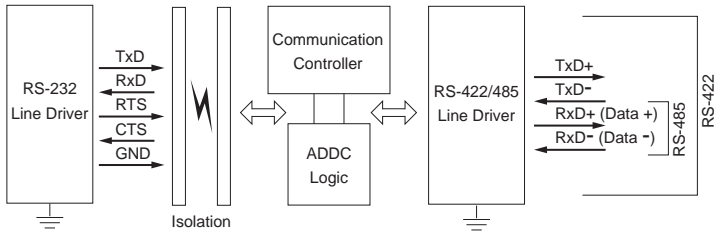

Isolation Block Diagram

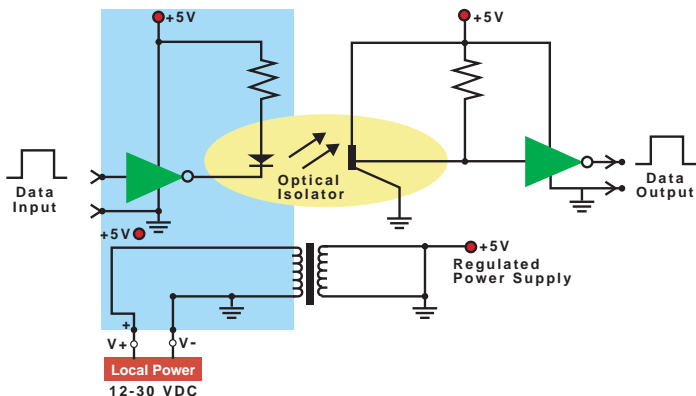

Typical Applications

RS-485 Application

A typical RS-485 application for TCC-100/100I is depicted in the following figure. In this scenario, two TCC-100I units are used to connect two PCs to an RS-485 network. The third TCC-100I is used to connect the PLC—which is designed for the RS-232 interface—to the RS-485 network. In this way, both PCs are able to interact with the PLC and the LCD Display.

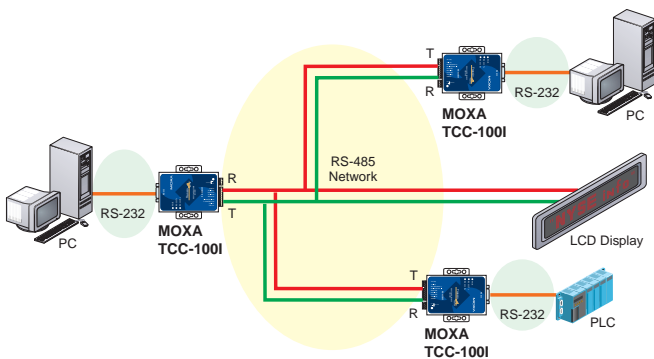

RS-422 Application

A typical RS-422 application for TCC-100/100I is depicted in the following figure. In this scenario, two TCC-100I units are used to create a point-to-point connection between a PC and Scales. The advantage of using two TCC-100I units to convert from RS-232, to RS-422, and then back to RS-232, is that the RS-422 cable connecting the two converters can be up to 1.2 km in length (this is quite an improvement compared to the 15-m distance limitation imposed by the RS-232 interface).

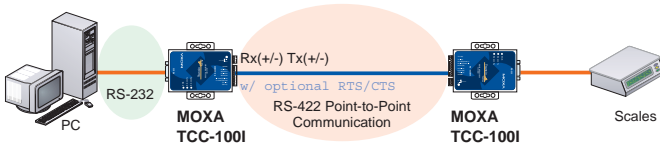

A

Service Information

In this appendix, we show you how to contact Moxa for information about this and other products, and how to report problems.

The following topics are covered:

- Moxa Internet Services**
- Problem Report Form**
- Product Return Procedure**
- Revision History**

Moxa Internet Services

Customer satisfaction is our number one concern, and to ensure that customers receive the full benefit of our products, Moxa Internet Services has been set up to provide technical support, driver updates, product information, and user's manual updates.

The following services are provided

E-mail for technical supportsupport@moxa.com.tw

World Wide Web (WWW) Site for product information:

..... <http://www.moxa.com>

Problem Report Form

Moxa TCC-100/100I

| | |
|-----------------------|--------------|
| Customer name: | |
| Company: | |
| Tel: | Fax: |
| Email: | Date: |

Moxa Product: TCC-100

TCC-100I

Serial Number: _____





Problem Description: Please describe the symptoms of the problem as clearly as possible, including any error messages you see. A clearly written description of the problem will allow us to reproduce the symptoms, and expedite the repair of your product.

Product Return Procedure

For product repair, exchange, or refund, the customer must:

- ◆ Provide evidence of original purchase.
- ◆ Obtain a Product Return Agreement (PRA) from the sales representative or dealer.
- ◆ Fill out the Problem Report Form (PRF). Include as much detail as possible for a shorter product repair time.
- ◆ Carefully pack the product in an anti-static package, and send it, pre-paid, to the dealer. The PRA should be visible on the outside of the package, and include a description of the problem, along with the return address and telephone number of a technical contact.

Revision History

| Document Edition | Revision Date | Revision Details |
|------------------|------------------|--|
| 2 nd | February 6, 2004 | <ol style="list-style-type: none"> Updated the edition of this user's guide on the title page. p. 2-2 Adjusted the Dip Switch figures. |
| 3 rd | June 9, 2004 | <ol style="list-style-type: none"> Updated the edition of this user's guide on the title page. Changed to the new Moxa logo on the title page. p. 1-2 Changed the product picture. p. 1-5 Changed "RS-232 Tx" to the  both in the text and in the figure. Changed the description of the  LED indicator when it is green. Changed "RS-232 Rx" to the  both in the text and in the figure. Changed the description of the  LED indicator when it is yellow. |
| 4 th | January 1, 2005 | <ol style="list-style-type: none"> Updated all figures. Edited the text. Change page size to 18x11.9cm |