

OnCell 5004/5104-HSPA Series

Industrial five-band GSM/GPRS/EDGE/UMTS/HSPA cellular routers



OnCell 5004-HSPA Series

OnCell 5104-HSPA Series

- > Five band UMTS/HSPA 800/850/AWS/1900/2100 MHz
- > Quad-band GSM/GPRS/EDGE 850/900/1800/1900 MHz
- > Cellular WAN and Ethernet WAN backup mechanism for a complete path redundancy
- > Primary and secondary power inputs for power source redundancy
- > GuaranLink and dual SIM redundancy for continuous cellular connections
- > Connect to 4 10/100BaseT(X) devices over an integrated VPN
- > Centralize private IP management with OnCell Central Manager
- > DIN rail and wall mountable housing
- > 2 digital inputs and 1 relay output (OnCell 5104-HSPA only)



Overview

The OnCell 5004/5104-HSPA series are high-performance industrial grade cellular routers that allow up to 4 Ethernet-based devices to simultaneously use a single cellular data account for primary or backup network connectivity to remote sites and devices. Both products provide the functionality of a cellular router, firewall, and switch in one device, and to ensure zero data loss and on-demand cellular communication, the OnCell 5004/5104-HSPA are integrated with the GuaranLink function. The difference between the OnCell 5004-HSPA and OnCell 5104-HSPA is that the OnCell 5104-HSPA comes

with a built-in relay output that can be configured to indicate the priority of events when notifying or warning engineers in the field, and the two digital inputs allow you to connect basic I/O devices, such as sensors, to the cellular network. The OnCell 5004-HSPA can be placed on a desktop or wall-mounted, whereas the OnCell 5104-HSPA has an IA design and can be attached to a DIN rail. Both products use 12 to 48 VDC power inputs with a screw-on design for greater reliability, and the Ethernet ports come with 1.5 kV magnetic isolation protection to keep your system safe from unexpected electrical discharges.

Specifications

Standards: GSM/GPRS/EDGE/UMTS/HSPA

Band Options:

- Five-band UMTS/HSPA 800/850/AWS/1900/2100 MHz
- Quad-band GSM/GPRS/EDGE 850/900/1800/1900 MHz

HSPA Data Rate: 14.4 Mbps DL, 5.76 Mbps UL

EDGE Multi-slot Class: Class 12

EDGE Data Rate: 237 Kbps DL, 237 Kbps UL

EDGE Terminal Device Class: Class B

GPRS Multi-slot Class: Class 12

GPRS Data Rate: 85.6 Kbps DL, 85.6 Kbps UL

GPRS Terminal Device Class: Class B

GPRS Coding Schemes: CS1 to CS4

Tx Power:

UMTS/HSPA: 0.25 W

EDGE900: 0.5 W

EDGE1800: 0.4 W

GSM1800: 1 W

GSM900: 2 W

WAN Interface

Number of Ports: 1

Ethernet: 10/100 Mbps, RJ45 connector, Auto MDI/MDIX

LAN Interface

Number of Ports: 4

Ethernet: 10/100 Mbps, RJ45 connector, auto MDI/MDIX

SIM Interface

Number of SIMs: 2

SIM Control: 3 V

I/O Interface (OnCell 5104-HSPA)

Alarm Contact: 1 relay output with current carrying capacity of 1 A @ 24 VDC

Digital Inputs: 2 electrically isolated inputs

- +13 to +30 V for state "1" (On)

- +3 to -30 V for state "0" (Off)

Software

Network Protocols: ARP, DDNS, DHCP/BOOTP, DNS Relay, HTTP, HTTPS, ICMP, IPSec, PPP, PPPoE, SMTP, SNMP, SSL, TCP/IP, Telnet, UDP

Routing/Firewall: NAT, port forwarding, WAN IP filtering, static route

Authentication: Local user-name and password

Cellular Connectivity: GuaranLink

Management Software

Utilities: OnCell Search Utility

Configuration and Management Options: SNMP v1/v2c/v3, Web/Telnet/Serial Console, SSH, Remote SMS Control, Auto IP Report

Private IP Solution: OnCell Central Manager

Physical Characteristics

Housing: Aluminum, providing IP30 protection

Weight:

OnCell 5004-HSPA: 505±5 g

OnCell 5104-HSPA: 645±5 g

Dimensions:

OnCell 5004-HSPA: 158 x 103 x 34 mm (6.22 x 4.06 x 1.34 in)

OnCell 5104-HSPA: 135 x 50.8 x 103 mm (5.315 x 2.00 x 4.16 in)

Environmental Limits

Operating Temperature:

Standard Models: -30 to 55°C (-22 to 131°F)

Wide Temp. Models: -30 to 70°C (-22 to 158°F)

Storage Temperature: -40 to 75°C (-40 to 167°F)

Ambient Relative Humidity: 5 to 95% (30°C, non-condensing)

Power Requirements

Number of Power Inputs:

OnCell 5004-HSPA: 1 terminal block, 1 power jack

OnCell 5104-HSPA: 10-pin terminal block with dual power input

Input Voltage: 12 to 48 VDC

Power Consumption:

OnCell 5004-HSPA: 12 to 48 VDC, 400 mA (idle), 900 mA (max.)

OnCell 5104-HSPA: 12 to 48 VDC, 450 mA (idle), 950 mA (max.)

Standards and Certifications

Safety: UL 60950-1

EMC: FCC Part 15 Subpart B Class A, EN 55022 Class A, EN 55024

Radio: FCC Part 22H, FCC Part 24E, EN 301 489-1, EN 301 489-7, EN

301 489-24, EN 301 511, EN 301 908

Reliability

MTBF (mean time between failures):

OnCell 5004-HSPA: 441,000 hrs

OnCell 5104-HSPA: 411,000 hrs

Warranty

Warranty Period: 5 years

Details: See www.moxa.com/warranty

Dimensions

OnCell 5004-HSPA

Unit: mm (inch)

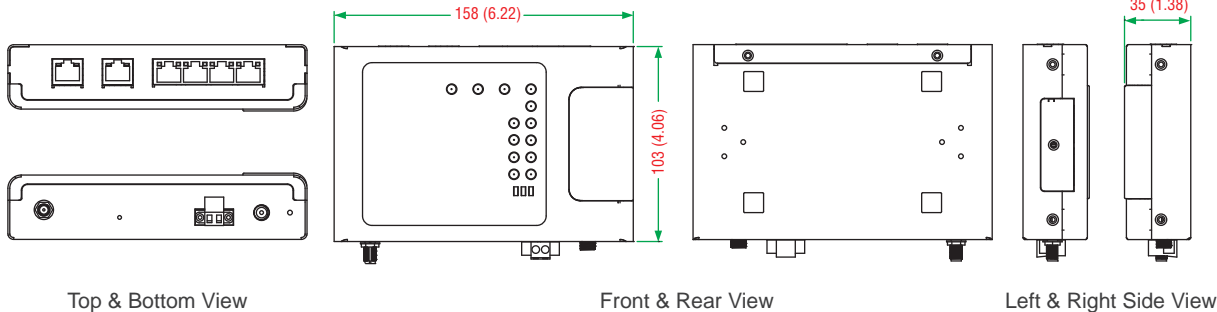

OnCell 5104-HSPA

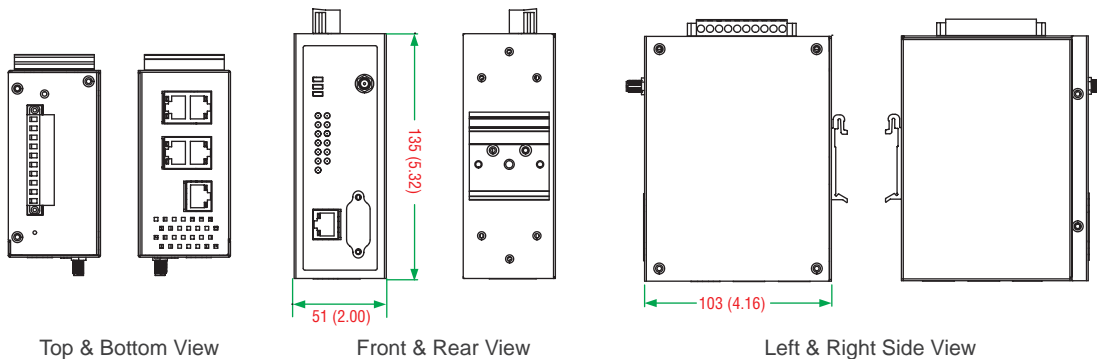

Ordering Information

Available Models

OnCell 5004-HSPA: 4 port Five-band industrial UMTS/HSPA Router, 10/100M Ethernet, RJ-45 8pin, 12-48VDC

OnCell 5104-HSPA: 4 port Five-band industrial UMTS/HSPA Router, 10/100M Ethernet, IA design, 12-48VDC

OnCell 5104-HSPA-T: 4 port Five-band industrial UMTS/HSPA Router, 10/100M Ethernet, IA design, 12-48VDC, -30 to 70°C

Note: Please visit Moxa's website for a complete list of optional wireless accessories and antennas available for Moxa's wireless products.

Package Checklist

- OnCell cellular router
- Rubber SMA antenna
- Rubber stand (OnCell 5004-HSPA only)
- Wallmount kit (OnCell 5004-HSPA only)
- DIN-rail kit (OnCell 5104-HSPA only)
- Documentation and software CD
- Quick installation guide (printed)
- Warranty card

Note: An activated SIM card (not included) must be provided by a third party Cellular Service Provider